



Specification – MV Composite Cross-arms

Standard Number: HPC-8MJ-07-0002-2018

Issue Date: 12th July 2018

Document Number: CS10# 10067687

Print Date: 25/07/2018

Uncontrolled document when downloaded. Refer to Horizon Power's website for most current version.

© Horizon Power Corporation 2016

| Document Control | | |
|---|--|--|
| Document Owner <i>(May also be the Process Owner)</i> | Name: Paul Savig Position: Senior Standards Engineer | |
| Approved By * | Name: Jose Duarte Position: Engineering Services Manager | |
| Approved By | Name: Marc Beckx Position: Manager Engineering and Project Services | |
| Date Created/Last Updated | July 2018 | |
| Review Frequency ** | Initial review frequency of 1 year, then every 3 years | |
| Next Review Date ** | July 2019 | |

* Shall be the Process Owner and is the person assigned authority and responsibility for managing the whole process, end-to-end, which may extend across more than one division and/or functions, in order to deliver agreed business results.

** This person will have the power to grant the process owner the authority and responsibility to manage the process from end to end.

*** Frequency period is dependent upon circumstances– maximum is 5 years from last issue, review, or revision whichever is the latest. If left blank, the default shall be 1 year unless otherwise specified.

| Revision Control | | |
|------------------|------------|-------------------------|
| Revision | Date | Description |
| 0 | 12/07/2018 | Original Document Issue |

| STAKEHOLDERS | |
|---|----------------------------------|
| <i>The following positions shall be consulted if an update or review is required:</i> | |
| <i>Manager Engineering & Project Services</i> | <i>Regional Asset Managers</i> |
| <i>Manager Asset Management Services</i> | <i>Manager Health and Safety</i> |

TABLE OF CONTENTS

| | | |
|----------|--|-----------|
| 1 | Introduction | 5 |
| 2 | Reference Documents | 5 |
| 3 | Definitions | 6 |
| 4 | Description | 6 |
| 4.1 | Dimensions..... | 7 |
| 4.2 | Loading Points & End Caps..... | 7 |
| 5 | Performance Criteria | 7 |
| 5.1 | Design Life..... | 7 |
| 5.2 | Strength..... | 7 |
| 5.2.1 | Applicable Loads..... | 7 |
| 5.2.2 | Serviceability..... | 8 |
| 5.3 | Electrical Properties..... | 8 |
| 5.4 | Durability..... | 9 |
| 5.5 | Maintenance..... | 9 |
| 5.6 | Environmental parameters..... | 9 |
| 5.7 | Compatibility and interchangeability..... | 9 |
| 5.8 | Weight..... | 9 |
| 5.9 | Storage and handling..... | 9 |
| 6 | Mechanical, Electrical and Durability Type Tests | 9 |
| 6.1 | Mechanical Tests..... | 9 |
| 6.2 | Electrical Tests..... | 9 |
| 6.2.1 | Tracking and Erosion Test..... | 10 |
| 6.3 | Durability Tests..... | 10 |
| 6.3.1 | Aging (UV with moisture)..... | 10 |
| 6.3.2 | Rainfall and high humidity..... | 10 |
| 6.3.3 | Resistance to Fire Damage..... | 10 |
| 6.4 | Batch Tests..... | 10 |
| 7 | Packaging and Equipment Identification requirements | 11 |
| 7.1 | Packaging..... | 11 |
| 7.2 | Material Traceability..... | 11 |
| 8 | Quality Assurance | 11 |
| 9 | Training | 11 |

| | |
|--|----|
| APPENDIX A Revision Information | 12 |
| APPENDIX B Quality Assurance (to be completed by stores) | 13 |
| APPENDIX C Schedules A & B..... | 15 |
| APPENDIX D Compliance Document | 16 |
| APPENDIX E Departures from Technical Specification | 18 |
| APPENDIX F Indicative Drawing of the Composite Cross-arm | 19 |
| APPENDIX G Intermediate Insulator Pin | 20 |
| APPENDIX H Strain/Termination Insulator Eye-Bolt..... | 21 |
| APPENDIX I 'T' Bracket..... | 22 |
| APPENDIX J 'Raiser' Brackets | 23 |

1 INTRODUCTION

This Specification details the requirements for manufacture, supply, testing and delivery of Composite Fibre cross-arms for use on overhead electricity distribution systems in an exposed environment. Horizon Power would like to use composite cross-arms to support medium voltage (<36 kV) bare aerial conductors. They are required to have the following properties which are either equivalent to or more advantageous to the traditional steel cross-arm:

- strength
- durability; and
- electrical properties

This Specification identifies the performance parameters, test requirements and information provided by the Preferred Vendor.

2 REFERENCE DOCUMENTS

All work and materials shall comply with the Standards and documents as referenced in the Document Control Section of this technical specification and all amendments issued from time to time except where varied by this Specification.

- [1]. *AS/NZS 1170.2:2011 Structural Design Actions – Wind Actions*, Standards Australia, available at <http://www.saiglobal.com>
- [2]. *AS 1199.1:2003 Sampling procedures for inspection by attributes - Sampling schemes indexed by acceptance quality limit (AQL) for lot-by-lot inspection*, Standards Australia, available at <http://www.saiglobal.com>
- [3]. *AS/NZS 7000:2016 Overhead Line Design – Detailed Procedures*, Standards Australia, available at <http://www.saiglobal.com>
- [4]. *AS/NZS ISO 9001 Quality management systems – Requirements*, Standards Australia, available at <http://www.saiglobal.com>
- [5]. *AS/NZS ISO 14001 Environmental management systems - Requirements with guidance for use*, Standards Australia, available at <http://www.saiglobal.com>
- [6]. *ASTM D2303 Standard Test Methods for Liquid-Contaminant, Inclined-Plane Tracking and Erosion of Insulating Materials*, American Society for Testing and Materials, available at <http://www.saiglobal.com>
- [7]. *ASTM G154 Standard Practice for Operating Fluorescent Ultraviolet (UV) Lamp Apparatus for Exposure of Nonmetallic Materials*, American Society for Testing and Materials, available at <http://www.saiglobal.com>
- [8]. *ENA Doc 012-2006 Cross-arm Supply and Performance Specification*, Energy Networks Association, available at <http://www.saiglobal.com>
- [9]. *Horizon Power Environmental Conditions HPC-9EJ-01-0001-2013*, Horizon Power, CS10# 2302921, available at <http://horizonpower.com.au/contractors-suppliers/contractors/manuals-and-standards/>
- [10]. *IEC 60587 Electrical insulating materials used under severe ambient conditions - Test methods for evaluating resistance to tracking and erosion*, International Electrotechnical Committee, available at <http://www.saiglobal.com>

[11]. IEC 60695 Fire hazard testing - Part 2-12: Glowing/hot-wire based test methods - Glow-wire flammability index (GWFI) test method for materials, International Electrotechnical Committee, available at <http://www.saiglobal.com>

[12]. JIS K 7015—1998 Pultruded Fibre-reinforced Plastics, Japanese Standards Association, available at <http://www.saiglobal.com>

3 DEFINITIONS

For the purposes of this specification, the following definitions shall apply:

Table 3-1: Definitions

| Term | Description |
|-------------------------------------|---|
| Design Life | The period over which the cross-arm is required to perform its function without repair which is 50 years |
| Characteristic Capacity | The characteristic capacity is based on statistical concepts and is the strength below which no more than 5% of all samples tested from the population will fail |
| Material strength factor (ϕ) | This factor takes into account variability of material and workmanship. The value used for ϕ varies from material to material and for composite material the required value is 0.75. |

4 DESCRIPTION

For the purposes of this Specification, the following descriptions shall apply;

- Intermediate Connection Cross-arm
- Termination/Strain Connection Cross-arm

The cross-arm arrangements at both intermediate and termination/strain locations are shown in Figure 4-1 and Figure 4-2. The intermediate cross-arm is attached to the pole with a pair of M16 king bolts and a 'T' bracket or a 'Raiser' bracket, whilst the termination/strain cross-arm is attached to the pole with a pair of M16 king bolts and a 'T' bracket. Refer to the 'T' and 'Raiser' Bracket drawings presented in Appendix I and J respectively.

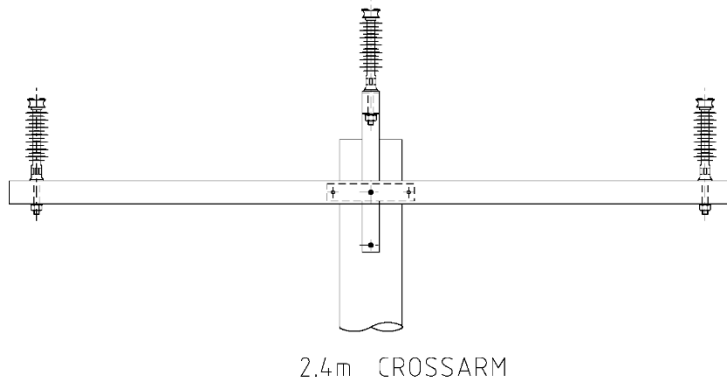

Figure 4-1: Typical arrangement at intermediate locations

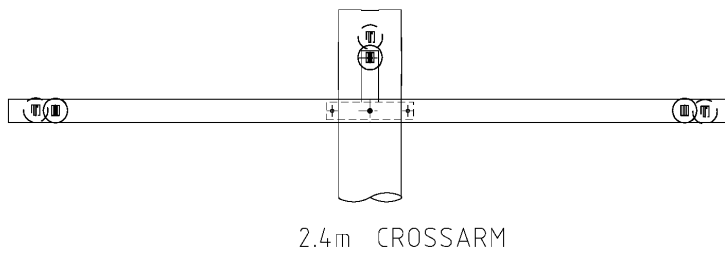

Figure 4-2: Typical arrangement at termination/strain locations

4.1 Dimensions

The manufacturing tolerance shall be as per Pultruded Fibre-reinforced Plastics JIS K 7015 – 1998 [12].

Critical dimensions of the cross-arm are specified in Appendix F. Tenderers shall propose suitable width, thickness and height of the cross-arm to meet the load requirements. The cross-arm shall have bolt hole sizes and critical dimensions compatible with the current hardware including;

- a) Post Insulator bolt dimension shown in Appendix G
- b) Strain/Termination eye-bolt dimension shown in Appendix H
- c) Mounting brackets dimension shown in Appendix I & J

4.2 Loading Points & End Caps

Any fillers, inserts or devices used to reinforce the strength of the cross-arm at loading points shall not protrude beyond the outside surface of the cross-arm.

Composite cross-arms shall have the ends capped by a non-conductive material that is impact resistant, secure, permanently fixed, and will not degrade during the service life of the cross-arm.

5 PERFORMANCE CRITERIA

Performance criteria shall be as per ENA DOC 012-2006 with the exceptions noted below [8]. Where ENA DOC 012-2006 refers to ESAA C(b) 1, this reference should be replaced with AS/NZS 7000:2016 [3].

5.1 Design Life

The design life should be at least 50 years.

Preferred Vendors must state the expected design service life of the cross-arm and submit their proposal/test report to validate the minimum design life.

5.2 Strength

5.2.1 Applicable Loads

The cross-arms must be able to withstand the dead loads, tensile loads, and wind loads under maximum wind condition presented in Table 5-1. In addition, the interaction of bending and axial (compression/tension) shall be verified as per Eurocomp Design Code or equivalent Standard (refer to the Technical Schedule requirements). The applicable material strength reduction factor ($\phi=0.75$) shall be considered in the cross-arm design.

The Preferred Vendor must submit the test result copies and the applicable calculations to confirm that the offered cross-arm is fit for purpose.

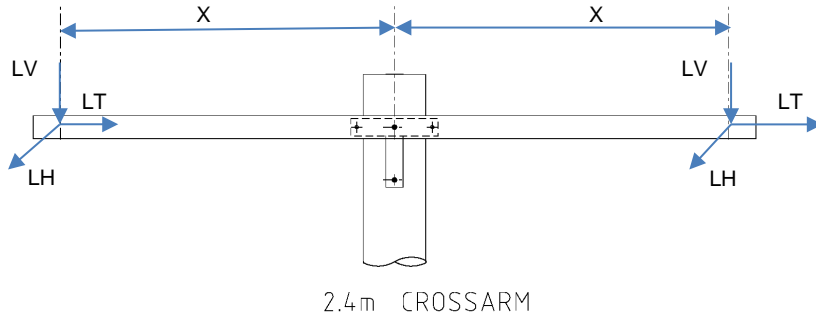

Figure 5-1: Cross-arm Action Requirements

Table 5-1: Cross-arm Design Requirements

| Load Description (Refer to Figure 5-1) | Intermediate Arrangement | Strain/Termination Arrangement |
|---|---|--------------------------------|
| LV (kN) | 3.2 | 0.6 |
| LT (kN) | 4.5 | 1.8 |
| LH (kN) | 4.2 | 22.4 |
| Distance between phase connection and centre point of the cross-arm (X) | 1.05 m (2.4 m cross-arm) 1.5 m (3 m cross-arm) | |
| Crush Resistance Torque with Washer for M16 bolt (ϕR_n) | 100.0 Nm | |
| Connection capacity at M16 connection (ϕR_n) | 40 kN | |
| Torsion Capacity (ϕR_n) | 3.0 kNm | |

5.2.2 Serviceability

As per Section 4.2.7 of ENA DOC 012-2006, the vertical deflection of the cross-arm due to dead load must be limited to a maximum of 5% of bendable length [8].

For termination arrangements, conductors are longitudinally connected and vendors are required to demonstrate deflection is within the 5% limit in the longitudinal direction.

5.3 Electrical Properties

As the composite cross-arms are electrically insulating they must meet the following minimum requirements in accordance with ENA DOC 012-2006 Clause 4.3 [8].

5.4 Durability

The Composite cross-arms must meet the durability requirements of ENA DOC 012 – 2006 for the 50 year design life [8]. The following durability performance is required:

- a) Resistance to attack by natural agents-both physical and biological
- b) Form and dimensional stability
- c) Performance of adhesives and mechanical fastening systems
- d) Resistance to fire damage
- e) Resistance to any forms of deterioration that would prevent the cross-arm from performing to its strength requirements in Clause 4.2 for a 50 year design life.

5.5 Maintenance

The cross-arm and any integrated fittings should preferably be maintenance free for the 50 year design life. Where this is not compliant the supplier must advise the required maintenance regime.

5.6 Environmental parameters

The Composite Fibre cross-arms to be supplied under this specification shall be suitable for a hostile outdoor environment as per the *Horizon Power Environmental Conditions* [9].

The cross-arm suppliers must provide an end-of-life strategy for their products. Ideally the product will be reused or recycled, with disposal being the least attractive option.

5.7 Compatibility and interchangeability

The Composite cross-arms must be compatible and interchangeable with the current cross-arms and hardware. Refer to Appendices for the current cross-arm and hardware drawings.

5.8 Weight

Refer to ENA DOC 012-2006 Clause 4.9 [8].

5.9 Storage and handling

Refer to ENA DOC 012-2006 Clause 4.10 [8].

6 MECHANICAL, ELECTRICAL AND DURABILITY TYPE TESTS

6.1 Mechanical Tests

Mechanical tests shall be carried in accordance with Clause 5.1 and 5.2 of ENA DOC 012-2006 [8].

6.2 Electrical Tests

Electrical tests shall be carried out in accordance with Clause 5.3, 5.4 and 5.5 of ENA DOC 012-2006 [8].

6.2.1 Tracking and Erosion Test

The Tracking and erosion test shall be carried out as per IEC 60587 [10] or ASTM D2303 [6].

Horizon Power may consider alternative test methodologies

6.3 Durability Tests

Horizon Power may consider alternative test methodologies.

6.3.1 Aging (UV with moisture)

Suppliers shall perform the ASTM G154 test using UVB lamps to generate UV radiation [7]. Specimens shall be exposed to repetitive cycles of light and moisture under controlled environmental conditions preferably in the ratio of 2:1. The entire test duration should be a minimum 5000 hours. After completion of the test, there shall be no degradation in the mechanical strength and material stiffness of the test sample. It is also required that the test sample does not exhibit any significant visual changes.

6.3.2 Rainfall and high humidity

In the event that there is moisture ingress, the Supplier should be able to substantiate with test results that cross-arm strength does not fall below the minimum required value and is still able to resist the required loads.

The cross-arm shall be soaked in water for 24 hours and it should be verified that there is no strength deterioration due to immersion in water.

6.3.3 Resistance to Fire Damage

The Supplier shall demonstrate that the Composite cross-arms have good resistance to pole top fires by passing a glow wire test as per IEC 60695-2-12 [11].

6.4 Batch Tests

Prior to delivery, the Supplier shall submit a sampling test plan in accordance with AS 1199.1-2003 "Sampling procedures for inspection by attributes" and nominate the test facility [2]. The test plan submission shall identify the cross-arms, quantity, and types of tests to be carried out including the frequency of the tests for each batch.

Batch Test Certificates shall be provided with each delivery upon request stating the batch number and that each cross-arm delivered meets all of the requirements in this specification. It is required that the batch test certificates be submitted to Horizon Power through electronic means before material delivery starts. Horizon Power reserves the right to request the original test certificate as and when required.

Other testing programs such as continuous in-line testing may be considered as an alternative to batch testing.

7 PACKAGING AND EQUIPMENT IDENTIFICATION REQUIREMENTS

7.1 Packaging

The composite cross-arms shall be supplied in the manufacturer's standard packaging and on standard size no-returnable pallets. The Supplier is required to nominate standard pack quantities and standard packs shall be clearly marked with the following information:

Manufacturer's Name or Trademark

Month and Year of Manufacture (e.g. 08/2013)

Horizon Power stock code of text height 20 – 30 mm (Code name shall be provided during award of the contract)

7.2 Material Traceability

The Supplier shall have a system in place whereby all material deliveries for cross-arms and/or cross-arm components used in the manufacture of the final cross-arm product, have recorded traceability to intermediate suppliers of such cross-arms and/or components including batch numbers.

8 QUALITY ASSURANCE

Horizon Power's prefers the Supplier to document and maintain a Quality System in conformance with AS/NZS ISO 9001 [4], or equivalent international standard and an environmental management system in conformance with AS/NZS ISO 14001 [5].

If the supplier decides to appoint a sub-vendor to supply any specific item or all of the items, then Horizon Power will require the sub-vendor/s to meet its Quality System requirements.

If the supplier is not accredited to AS/NZS ISO 9001 [4] and AS/NZS ISO 14001 [5], they must supply Horizon Power with details of their in-house quality and environmental management systems.

9 TRAINING

Training material in the form of drawings, instructions and/or audio visuals are required to be provided for the items accepted under the offer.

Training Material may include but is not limited to the following topics:

- a) Handling and storage
- b) Installation
- c) Maintenance
- d) Disposal at the end of service life

APPENDIX A REVISION INFORMATION

(Informative) Horizon Power has endeavoured to provide standards of the highest quality and would appreciate notification of errors or queries.

Each Standard makes use of its own comment sheet which is maintained throughout the life of the standard, which lists all comments made by stakeholders regarding the standard.

A comment sheet found in **CS10# 10067761** can be used to record any errors or queries found in or pertaining to this standard. This comment sheet will be referred to each time the standard is updated.

| Date | Rev No. | Notes |
|-----------|---------|---------------------------|
| 7/06/2018 | 0 | Initial Document Creation |
| | | |
| | | |

APPENDIX B QUALITY ASSURANCE (TO BE COMPLETED BY STORES)

| | | | | | | | | | | |
|---------------------------|-------------------------------------|---------------------------|--|--|-------------------|----------------|---------------------------|-----------------------------------|--------------------|-----------------|
| DOCUMENT NUMBER | | HPC-8MJ-07-0002-2018 | |  | | | QUALITY ASSURANCE | | CS NUMBER | |
| DEVICE DESCRIPTION | | LABEL MATERIAL NO. | | | | | LUMINAIRE PURCHASE | | ASSET OWNER | |
| | | ASSET ID/ STOCK NO | | | | | | | | |
| MANUFACTURER | | | | DIMENSION | | | | | | |
| ITEM | OPERATION/EQUIPMENT/FACILITY | | | DOCUMENT REF. | WHO CHECKS | INITIAL | DATE/ TIME | QUALITY ASSURANCE CRITERIA | PASS Y/N | COMMENTS |
| 1 | | | | | | | | | | |
| 1.1 | Name of Manufacturer | | | | | | | ***** | | |
| 1.2 | Week & Year of Manufacture | | | | | | | ***** | | |
| 1.3 | Horizon Power Order Number | | | | | | | ***** | | |
| 1.4 | Horizon Power Stock Number | | | | | | | ***** | | |
| 1.5 | Size (length x height x width) | | | | | | | ***** | | |
| 1.6 | Weight | | | | | | | ***** | | |
| 1.7 | Batch Number | | | | | | | ***** | | |
| 1.8 | Physical Appearance | | | | | | | ***** | | |
| 1.9 | Pallet Quantity | | | | | | | ***** | | |
| 1.10 | Pallet Weight | | | | | | | ***** | | |

| ITEM | OPERATION/EQUIPMENT/FACILITY | DOCUMENT REF. | WHO CHECKS | INITIAL | DATE/TIME | QUALITY ASSURANCE CRITERIA | PASS Y/N | COMMENTS |
|---------------------------|-----------------------------------|---------------|------------|---------|-----------|-------------------------------|----------|----------|
| 2 | DOCUMENTATION | | | | | | | |
| 2.1 | Material Safety Data Sheets | | | | | Clear, Legible and in English | | |
| 2.2 | Batch Test and Inspection Reports | | | | | Clear, Legible and in English | | |
| SYMBOLS AND ABBREVIATIONS | | | | | | | | |
| H = HOLD POINT | S = SUPERVISOR | | | | | | | |
| W = WITNESS POINT | T = TECHNICIAN, EL = ELECTRICIAN | REVISION | | | | | | |
| V = VERIFICATION POINT | E = ENGINEER | DATE | | | | | | |
| S/C = SUBCONTRACTOR | PM = PROJECT MANAGER | APPROVED BY | | | | | | |

APPENDIX C SCHEDULES A & B

| | | |
|---|-----------------------|----------------------|
|  | SPECIFICATION ENQUIRY | HPC-8MJ-07-0002-2018 |
| | VENDOR'S NAME | |
| | DATE | |

**TECHNICAL SCHEDULES
ITEMS: MV Composite Cross-arms**

| | | |
|--------------------|--------------|----------------------|
| Arrangement | Intermediate | Strain / Termination |
| | 1.1 | 1.2 |

SCHEDULE A : Horizon Power's specific requirements

SCHEDULE B: Particulars to be completed by Vendor for each ITEM offered

| No | Clause | Description | Schedule A | Schedule B |
|----------|--------|--------------------------------------|------------|------------|
| 1 | | General | | |
| 1.1 | 11 | Manufacturer | | |
| 1.2 | | Brand / Catalogue No. / Model | | |
| 1.3 | | Country of Manufacture | | |
| 2 | | Dimensions | | |
| 2.1 | 4.1 | Width (mm) | | |
| 2.2 | 4.1 | Height (mm) | | |
| 2.3 | 4.1 | Length (mm) | | |
| 2.4 | 5.8 | Mass (kg) | | |
| 3 | | Particulars of Cross-arm | | |
| 3.1 | 4.2 | Loading points and End caps | | |
| 3.2 | 5.1 | Design life (years) | ≥ 50 | |
| 3.3 | 5.2.1 | Power Factor | ≥ 0.9 | |
| 3.4 | 5.2.2 | Serviceability (%) | ≤ 5% | |
| 3.5 | 5.3 | Electrical Properties | | |
| 3.6 | 5.4 | Durability | | |
| 3.7 | 5.5 | Maintenance | | |
| 3.8 | 5.6 | Environmental Parameters | | |
| 3.9 | 5.7 | Compatibility and Interchangeability | | |
| 3.10 | 5.8 | Weight | | |
| 3.11 | 5.9 | Storage and Handling | | |

APPENDIX D COMPLIANCE DOCUMENT

The Vendor shall indicate below whether this offer is fully compliant with the nominated clause in this Specification. A YES shall ONLY be indicated if the offer is 100% compliant with the relevant clause. If NO is indicated and supporting documents are submitted, then mark the ATT box with the attachment number.

| CLAUSE NUMBER | | YES | NO | ATT. |
|---------------|--|--------------------------|--------------------------|--------------------------|
| 1. | INTRODUCTION | | | |
| 2. | REFERENCE DOCUMENTS | | | |
| 3. | DEFINITIONS | | | |
| 4. | DESCRIPTION | | | |
| 4.1 | Dimensions | <input type="checkbox"/> | <input type="checkbox"/> | <input type="checkbox"/> |
| 4.2 | Loading Points & End Caps | <input type="checkbox"/> | <input type="checkbox"/> | <input type="checkbox"/> |
| 5. | PERFORMANCE CRITERIA | | | |
| 5.1 | Design Life | <input type="checkbox"/> | <input type="checkbox"/> | <input type="checkbox"/> |
| 5.2 | Strength | | | |
| 5.2.1 | <i>Applicable Loads</i> | <input type="checkbox"/> | <input type="checkbox"/> | <input type="checkbox"/> |
| 5.2.2 | <i>Serviceability</i> | <input type="checkbox"/> | <input type="checkbox"/> | <input type="checkbox"/> |
| 5.3 | Electrical Properties | <input type="checkbox"/> | <input type="checkbox"/> | <input type="checkbox"/> |
| 5.4 | Durability | <input type="checkbox"/> | <input type="checkbox"/> | <input type="checkbox"/> |
| 5.5 | Maintenance | <input type="checkbox"/> | <input type="checkbox"/> | <input type="checkbox"/> |
| 5.6 | Environmental Parameters | <input type="checkbox"/> | <input type="checkbox"/> | <input type="checkbox"/> |
| 5.7 | Compatibility and Interchangeability | <input type="checkbox"/> | <input type="checkbox"/> | <input type="checkbox"/> |
| 5.8 | Weight | <input type="checkbox"/> | <input type="checkbox"/> | <input type="checkbox"/> |
| 5.9 | Storage and Handling | <input type="checkbox"/> | <input type="checkbox"/> | <input type="checkbox"/> |
| 6. | MECHANICAL, ELECTRICAL AND DURABILITY TYPE TESTS | | | |
| 6.1 | Mechanical Tests | <input type="checkbox"/> | <input type="checkbox"/> | <input type="checkbox"/> |
| 6.2 | Electrical Tests | <input type="checkbox"/> | <input type="checkbox"/> | <input type="checkbox"/> |
| 6.2.1 | <i>Tracking and Erosion Test</i> | <input type="checkbox"/> | <input type="checkbox"/> | <input type="checkbox"/> |
| 6.3 | Durability Tests | | | |
| 6.3.1 | <i>Aging (UV with moisture)</i> | <input type="checkbox"/> | <input type="checkbox"/> | <input type="checkbox"/> |
| 6.3.2 | <i>Rainfall and High Humidity</i> | <input type="checkbox"/> | <input type="checkbox"/> | <input type="checkbox"/> |
| 6.3.3 | <i>Resistance to Fire Damage</i> | <input type="checkbox"/> | <input type="checkbox"/> | <input type="checkbox"/> |
| 6.4 | Batch Tests | <input type="checkbox"/> | <input type="checkbox"/> | <input type="checkbox"/> |

| CLAUSE NUMBER | | YES | NO | ATT. |
|---------------|---|--------------------------|--------------------------|--------------------------|
| 7. | PACKAGING AND EQUIPMENT IDENTIFICATION REQUIREMENTS | | | |
| 7.1 | Packaging | <input type="checkbox"/> | <input type="checkbox"/> | <input type="checkbox"/> |
| 7.2 | Material Traceability | <input type="checkbox"/> | <input type="checkbox"/> | <input type="checkbox"/> |
| 8. | QUALITY ASSURANCE | <input type="checkbox"/> | <input type="checkbox"/> | <input type="checkbox"/> |
| 9. | TRAINING | <input type="checkbox"/> | <input type="checkbox"/> | <input type="checkbox"/> |

APPENDIX E DEPARTURES FROM TECHNICAL SPECIFICATION

The Vendor shall nominate the clause and describe the departure:

| CLAUSE NO | DEPARTURE |
|-----------|-----------|
| | |
| | |
| | |
| | |
| | |
| | |
| | |
| | |
| | |
| | |
| | |
| | |
| | |
| | |
| | |
| | |
| | |
| | |
| | |
| | |
| | |
| | |
| | |
| | |
| | |
| | |
| | |
| | |
| | |
| | |
| | |
| | |
| | |
| | |
| | |
| | |
| | |
| | |
| | |
| | |
| | |
| | |
| | |
| | |

APPENDIX F INDICATIVE DRAWING OF THE COMPOSITE CROSS-ARM

Cross-arm 3300 mm

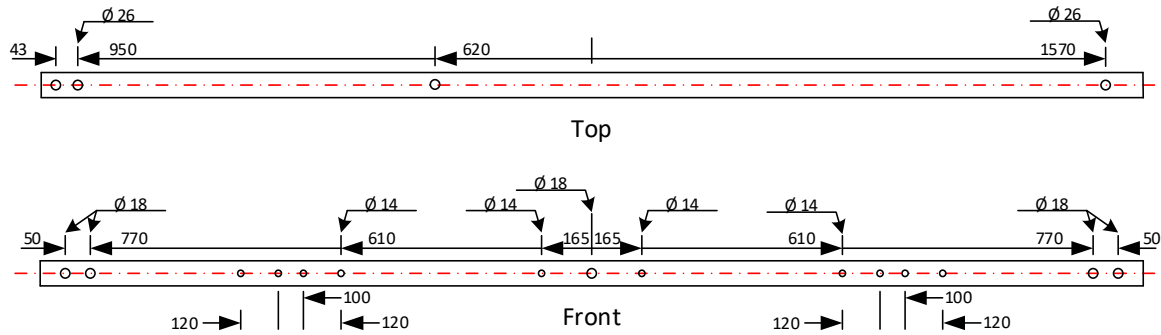

Cross-arm 2400 mm

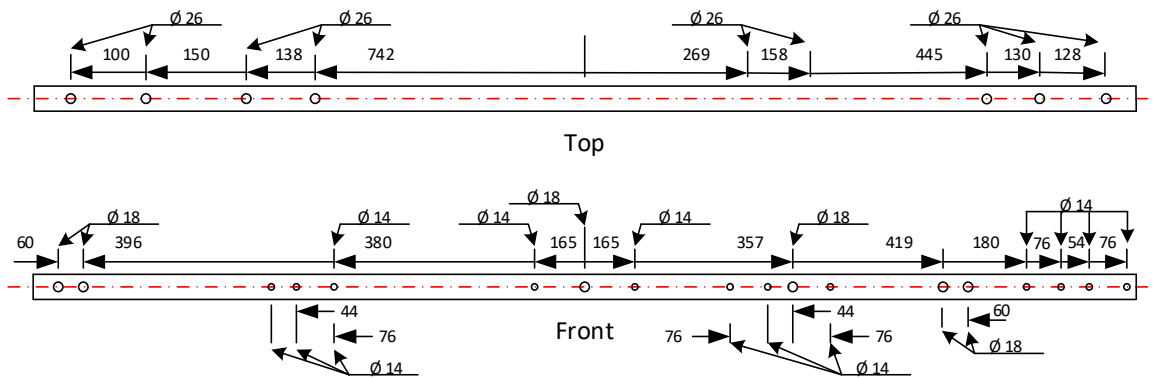

APPENDIX G INTERMEDIATE INSULATOR PIN

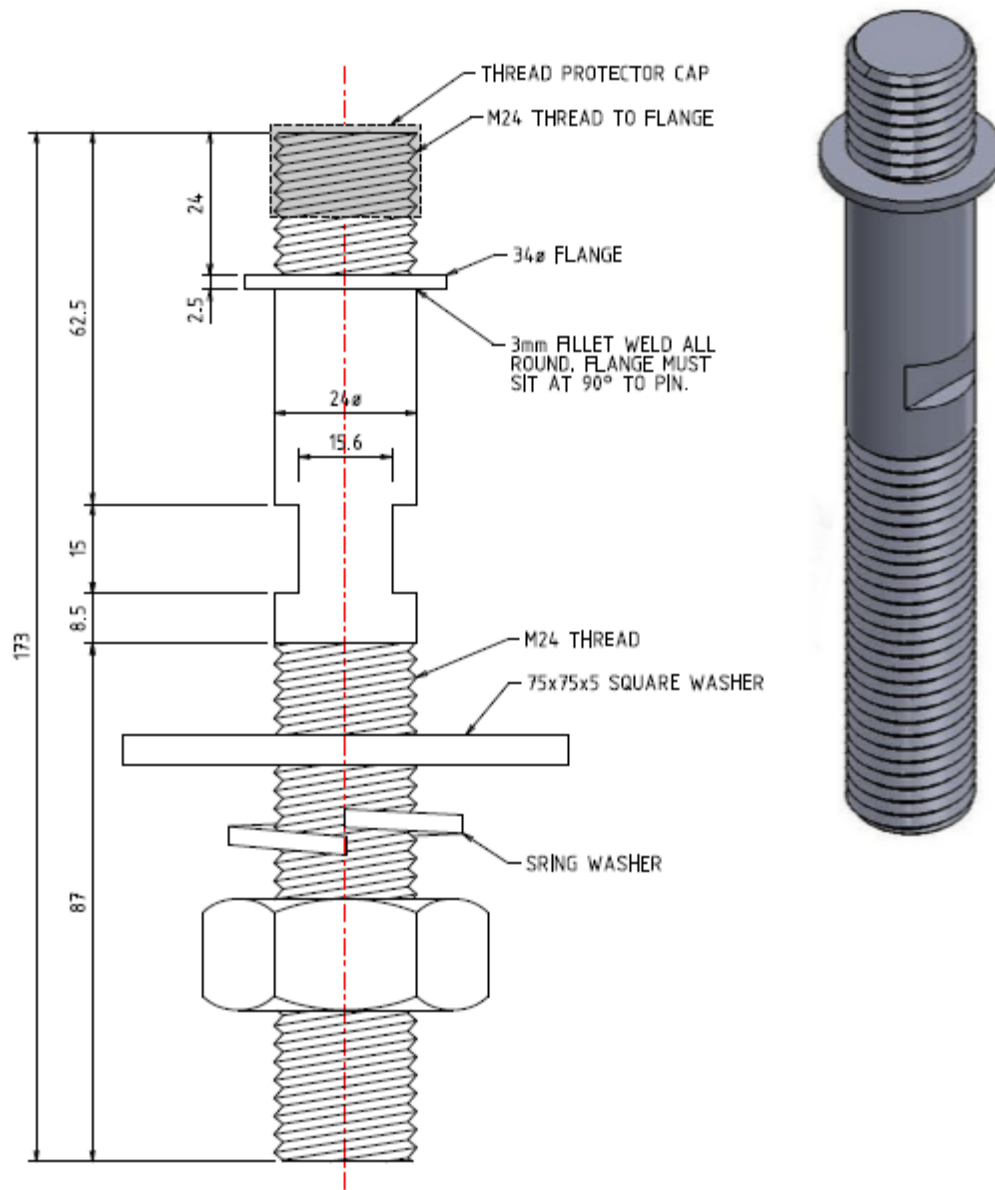

NOTES:

1. ALL DIMENSIONS ARE IN MILLIMETRES.
2. STEEL MATERIAL SHOULD BE GRADE 4.6 OR EQUIVALENT.
3. AFTER FABRICATION ALL BURRS AND SHARP EDGES TO BE REMOVED.
4. MATERIAL TO BE HOT DIP GALVANISED AS PER AS/NZS 4680 OR EQUIVALENT.
5. CONICAL SPRING WASHER TO BE GALV. SPRING STEEL (RANGE 2) TO AS/NZS 1472 OR EQUIVALENT.

STOCK CODE: AB4822

APPENDIX H STRAIN/TERMINATION INSULATOR EYE-BOLT

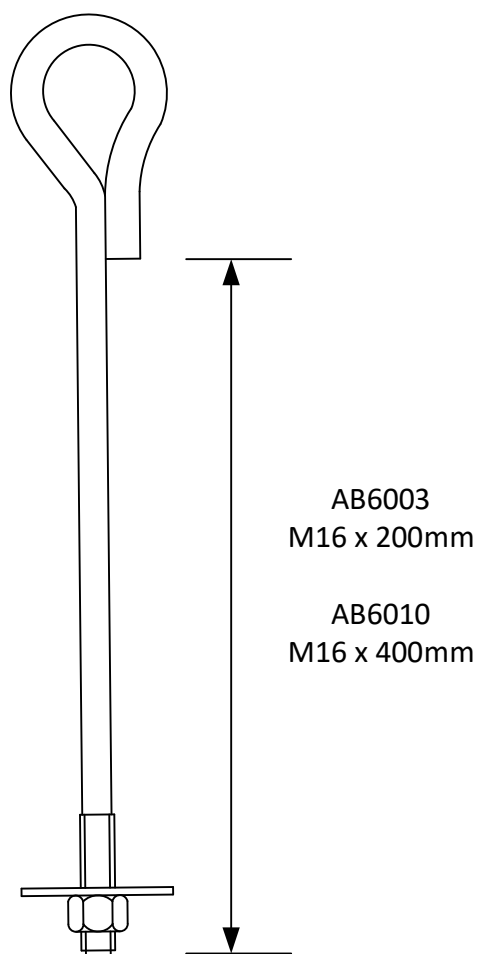

APPENDIX I 'T' BRACKET

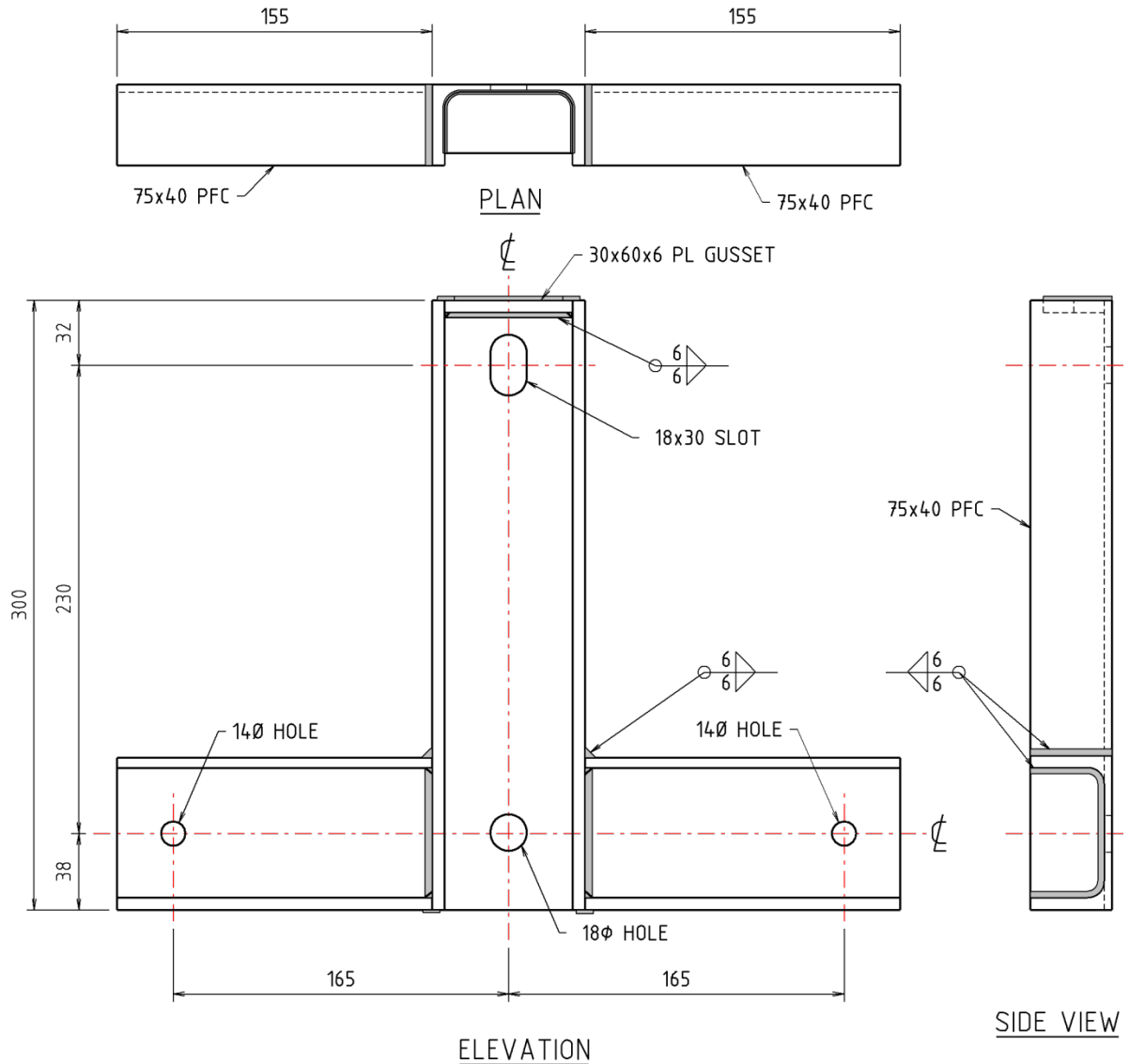

NOTES:-

1. ALL DIMENSIONS ARE IN MILLIMETRES.
2. NO FABRICATED ELEMENT OR COMPONENT IS TO BE FABRICATED FROM SHORT-PIECES.
3. WELDS TO BE 6mm FILLET (STRENGTH NOT LESS THAN 0.733kN/mm) AND TO BE AS PER AS/NZS 1554.1 TO GP STANDARD UNO.
4. WELD SYMBOLS SHOWN ARE TO AS 1101.3.
5. MATERIALS TO BE HOT DIP GALVANISED AS PER AS/NZS 4680D OR EQUIVALENT.
6. STEEL HOT ROLLED SECTIONS TO COMPLY WITH AS/NZS 3679.1 OR EQUIVALENT.
7. SS REFER TO STAINLESS STEEL Gr304.

STOCK CODE: CB3025

APPENDIX J 'RAISER' BRACKETS

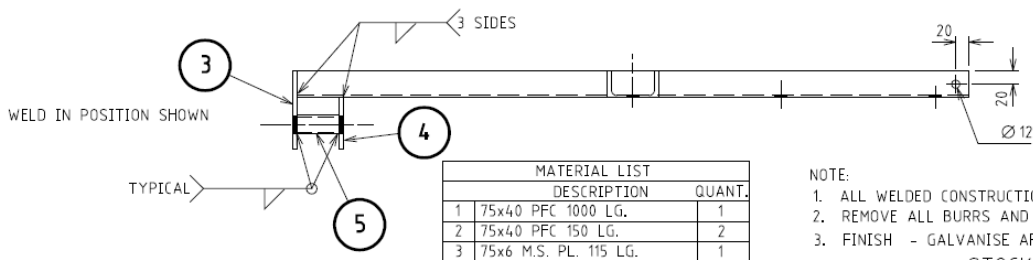
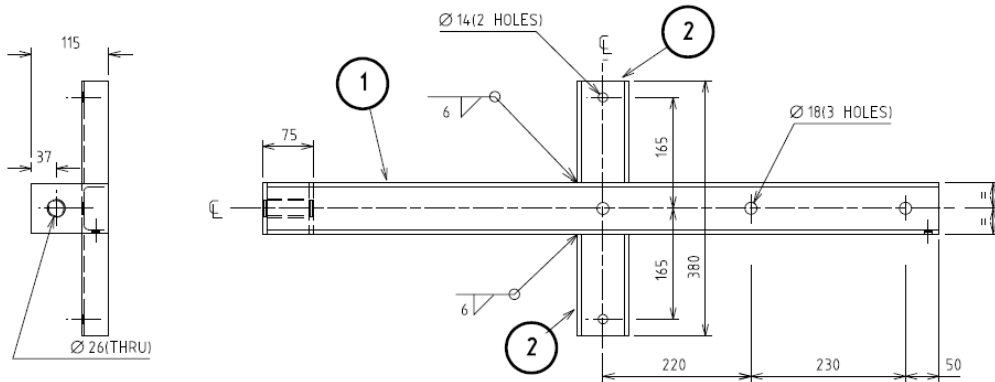

| MATERIAL LIST | |
|-------------------------|--------|
| DESCRIPTION | QUANT. |
| 1 75x40 PFC 1000 LG. | 1 |
| 2 75x40 PFC 150 LG. | 2 |
| 3 75x6 M.S. PL. 115 LG. | 1 |
| 4 75x6 M.S. PL. 75 LG. | 1 |
| 5 25 NB MED PIPE 63 LG. | 1 |

NOTE:
 1. ALL WELDED CONSTRUCTION.
 2. REMOVE ALL BURRS AND SHARP EDGES.
 3. FINISH - GALVANISE AFTER FABRICATION

STOCK No. CR1038
 P/N 0025

| MATERIAL LIST | |
|-------------------------|--------|
| DESCRIPTION | QUANT. |
| 1 75x40 PFC 635 LG. | 1 |
| 2 75x40 PFC 150 LG. | 2 |
| 3 75x6 M.S. PL. 115 LG. | 1 |
| 4 75x6 M.S. PL. 75 LG. | 1 |
| 5 25 NB MED PIPE 63 LG. | 1 |

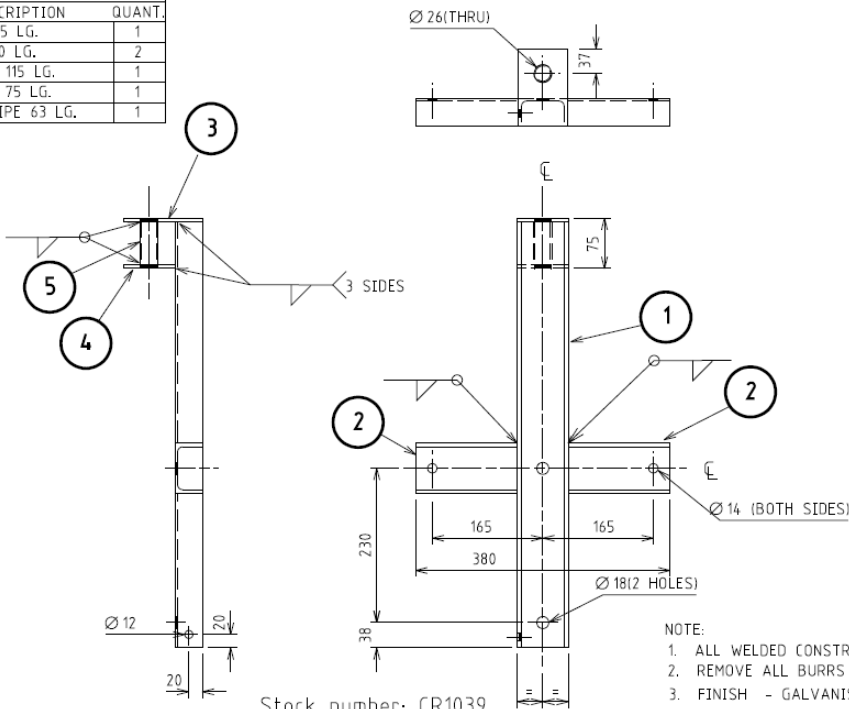

NOTE:
 1. ALL WELDED CONSTRUCTION.
 2. REMOVE ALL BURRS AND SHARP EDGES.
 3. FINISH - GALVANISE AFTER FABRICATION

Stock number: CR1039
 P/N 0067

| | |
|-------------------------------|------|
| Drawn | JS M |
| Checked | |
| Date | 7/03 |
| HEAD MODIFIED | |
| MATERIAL LIST ADDED. | |
| Drawn | RJP |
| Checked | |
| Date | 4/98 |
| DIM 100 WAS 100 DIM 38 WAS 48 | |
| 25MP'S PIPE ADDED. | |
| PLATES POSITION REVISED. | |